

# Revision of the Malagasy genus *Calyptranthera* (Asclepiadaceae)

**Jens KLACKENBERG**

Naturhistoriska riksmuseet, Sektionen för fanerogambotani,  
Box 50007, S-104 05 Stockholm, Sweden.  
klack@nr.m.se

---

**KEY WORDS**  
*Calyptranthera*,  
Asclepiadaceae,  
Madagascar.

## **ABSTRACT**

The Malagasy endemic genus *Calyptranthera* (Asclepiadaceae) is revised. Five species are recognized. Four new species are described, viz. *C. baronii*, *C. brevicaudata*, *C. grandiflora* and *C. pubipetala*. The morphological structure of the flower is discussed and a key, descriptions, the distribution and drawings of all taxa are given. A hypothesis of the cladistic relationship of the species is presented. Phytogeography and vicariance patterns are discussed.

**MOTS CLÉS**  
*Calyptranthera*,  
Asclepiadaceae,  
Madagascar.

## **RÉSUMÉ**

Révision du genre *Calyptranthera* (Asclepiadaceae), endémique de Madagascar. Cinq espèces sont reconnues. Quatre nouvelles espèces sont décrites : *C. baronii*, *C. brevicaudata*, *C. grandiflora* et *C. pubipetala*. La structure morphologique de la fleur est discutée ; une clé de détermination, les descriptions, la distribution et des illustrations de tous les taxons sont données. Une hypothèse indiquant les affinités phylogénétiques des espèces est proposée. Les données relatives à la phytogéographie et à la vicariance sont discutées.

---

## INTRODUCTION

The genus *Calyptranthera* was described recently (KLACKENBERG 1996a: 27) from only one collection with few flowers. This species had previously been placed in *Toxocarpus*. After having examined unidentified Asclepiadaceae material from the Kew, Missouri and Paris herbaria, additional collections belonging to the genus have been found, and *Calyptranthera* now comprises 5 species, all found in East Madagascar.

*Calyptranthera* has pollinaria with four pollinia each and is placed in tribe Secamoneae, close to the genus *Pervillea* (KLACKENBERG 1996b). It is characterized by its long projecting connectives as well as by having a discoid style head which narrows abruptly into a style which is topped by a short broad upper part. This structure is found also in many Periplocoideae, but not in *Secamone*, *Toxocarpus* or *Genianthus*. Furthermore, *Calyptranthera* has the four pollinia glued to a very thin U-shaped folded corpusculum which lacks caudicles. These characters, distinguishing *Calyptranthera* from *Secamone*, *Toxocarpus* and *Genianthus*, reveal similarities with the Malagasy endemic genus *Pervillea*.

*Calyptranthera* differs in several other characters from both *Pervillea*, *Secamone*, *Toxocarpus* and *Genianthus*, e.g., cup-like projections on the filaments below the anther wings forming the pollinium entrances, the shape of the corona lobes, and a thin, hairy submarginal fold on the corolla lobes. The latter character is absent, however, in *Calyptranthera brevicaudata* and *C. pubipetala*. Furthermore, the type species, *C. caudiclava*, has fused connectives forming a calyptra at the top of the gynostegium and club-shaped appendages on long strings at the top of the prolonged connectives. None of these features have been observed elsewhere in the tribe Secamoneae.

*Calyptranthera* is closely related to *Pervillea* (KLACKENBERG 1996b) but lacks the unique feature of distinctly curled leaf hairs with much reduced or totally lacking lumen which are characteristic of *Pervillea*.

## MATERIAL AND METHODS

This study is based on herbarium material from K, MO and P herbaria (abbreviations according to HOLMGREN et al. 1990). All specimens cited have been studied.

The species concept used in this revision conforms to KLACKENBERG (1992b: 597) and the spellings of geographical names are in accordance with the guidelines given in KLACKENBERG (1992a: 7).

Measurements of floral parts were made on boiled material and of the vegetative parts on dry material.

## MORPHOLOGY

**Habit:** The genus *Calyptranthera* consists of suffrutescent lianas with white latex. There exists only one collection with any indication of height, viz. 2 metres, but they can probably become much taller.

**Stem:** The stem is terete and covered with reddish hairs. The hairs are more or less erect but often bent. They consist of three small basal cells and one large, acute apical cell (Fig. 1C).

**Leaves:** The leaves have an elliptic to elongate or obovate lamina and a distinct petiole. The lamina is slightly coriaceous. Basal primary nerves often diverge from the midrib at an angle of ca. 90° or sometimes more, i.e. back-wards. Furthermore, they project on the upper side when dry, at least near the midrib. The petioles are often bent or twisted. There is sometimes one short and truncate gland at base of the lamina above (Fig. 1B). Glands (colleters) in this position have not been seen in Malagasy Secamoneae other than *Calyptranthera*, but are characteristic of, e.g., Asian *Toxocarpus* and *Genianthus*, and are also found in some Apocynaceae, Periplocoideae and are common in other tribes of Asclepiadoideae. In other taxa these glands are more or less ellipsoidal, however, and the short and truncate ones found in *Calyptranthera* have not been observed elsewhere within the tribe.

**Inflorescence:** The inflorescences occupy an extra-axillary position, which is in accordance with the majority of Asclepiadaceae. They constitute a cyme consisting of a terminal flower and a reduced axillary shoot topped by a flower at each node of the inflorescence. The second axillary shoot continues the growth of the inflo-

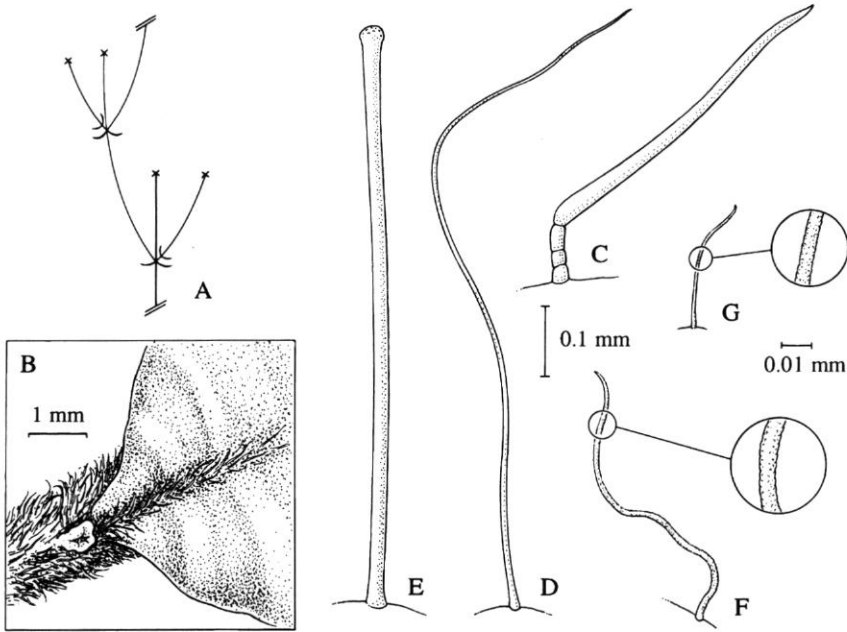

Fig. 1.—Morphology of *Calyptranthera*: **A**, diagram of inflorescence structure; **B**, gland at petiole near base of leaf lamina; **C**, reddish hairs on vegetative parts; **D**, hairs from near base of corolla lobes; **E**, bulbous hairs situated submarginally near base of corolla lobes; **F**, wavy hairs from corolla lobes; **G**, hairs from margin of corolla lobes. (B, D, E, *Capuron 28969*; C, F, *RN-5702*; G, *Capuron 18229bis*).

rescence (Fig. 1A). This is easily observed in *C. baronii* and *C. grandiflora* and usually also in *C. caudiclava*, which have more or less elongated inflorescences, but is somewhat less distinct in *C. brevicaudata* and *C. pubipetala*, which have more compact inflorescences with reduced internodes.

**Calyx:** The lobes of the calyx are free, linear to ovate and covered by reddish hairs. One to two more or less filiform colleters with darker apices are found at the lobe sinuses.

**Corolla:** The corolla lobes are united only shortly into a tube. They are usually glabrous except for a few mm-long hairy patch near the mouth. This indumentum consists of both long, more or less straight hairs with a smooth surface (Fig. 1D) and shorter wavy ones. In one species, *C. pubipetala*, most of the upper surface of the corolla lobes is covered by a shaggy indumentum of wavy hairs tapering towards the apex (Fig. 1F). In three species, *C. baronii*, *C. caudiclava* and *C. grandiflora*, there is a submarginal line of long hairs along a few mm near the mouth of the tube (Fig. 6B). This line is sometimes situated on

a small fold on the corolla. These hairs are unique to *Calyptranthera* within the tribe Secamoneae. They are long and straight with a blunt, usually bulb-like apex (Fig. 1E). The cuticular surface is somewhat rough. Furthermore, *C. baronii* and *C. grandiflora* have corolla lobes with ciliate hairs along the left margins (Fig. 1G) and with some small straight hairs scattered along the main nerves on the upper surface. The ciliate hairs have the same rather rough cuticular surface as the hairs found at the base of the corolla lobes in all other species. The longer, wavy hairs of *C. pubipetala* are also furnished with this rough cuticle.

The corolla has usually seven more or less straight nerves from the base to the apex or upper part of each lobe (Fig. 7B). *C. caudiclava*, however, has only three major nerves running from base to tip, and the lateral ones are forked several times turning outwards (Fig. 5C).

The corolla is reported as being greenish or white to lavender or purple. Probably the same flower changes colour with age.

**Androecium:** The five stamens are united to different degrees forming a cylinder around the style and style head. The filaments are broad and always coalescent. This filament tube is short in *C. brevicaudata* and *C. pubipetala*, but distinct and up to 1.5 mm high in, e.g., *C. caudiclava* (Fig. 2D). The upper parts of the filaments are furnished with cup-like projections forming the pollinium entrances (Fig. 2E, 7C). They are situated immediately below a pair of short anther wings (Fig. 2F). The coronal lobes are placed just below the thecae at the top of the broadened filaments (Fig. 2H). In *C. brevicaudata*, *C. caudiclava*

and *C. pubipetala* the lobes are spatulate to almost club-like directed more or less horizontally. In contrast to these, *C. baronii* and *C. grandiflora* have long and filiform coronal lobes directed upwards. The coronal lobes are usually covered by obtuse papillae.

The thecae are separated by a broad connective. The rims of the thecae are usually covered by abundant pointed papillae. The connectives are more or less prolonged. In *C. brevicaudata* and *C. pubipetala* they are relatively short and triangular, erecto-patent with the apices pointing towards each other forming a cone above the

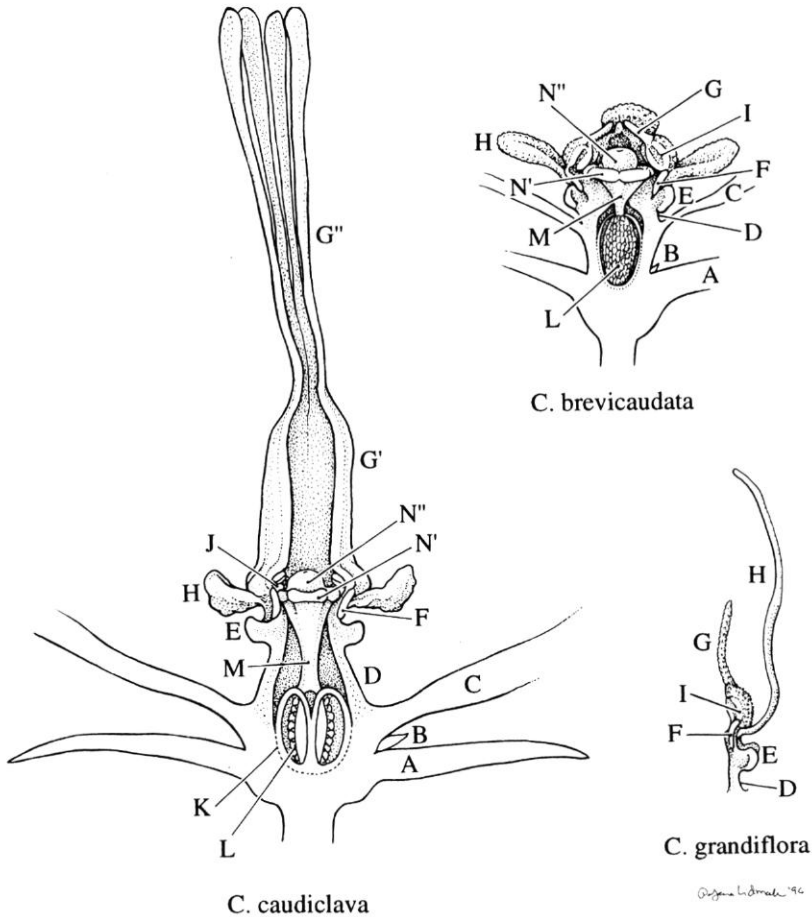

Fig. 2.—Structure of the flower of *Calyptrotrichia*: A, calyx lobe; B, colleter; C, corolla; D, filament tube; E, cup-like projection of filament tube (pollinaria entrance); F, anther wing; G, prolonged connectives (G', calyptro of broadened connectives; G'', club-shaped connective appendages); H, corona lobe; I, theca; J, pollinarium; K, ovary; L, placenta and ovules; M, style; N, stigma head (N', lower discoid part; N'', upper narrower part).

style head. In *C. baronii* and *C. grandiflora* the connectives are prolonged further, becoming filiform. In *C. grandiflora* the filiform apices of the connectives adhere to each other forming a column with five free basal pillars above the style head. This condition is further elaborated in *C. caudiclava*, where the basal parts of the connectives are broadened and coalescent forming a calyptra several mm high above the style head (Fig. 2G', 5D). At the top of this calyptra the five connectives become filiform and free from each other for a very short distance and then united again. The calyptra is topped by five free filiform appendages, which are somewhat club-shaped at the apices (Fig. 2G'', 5D). The prolonged connectives are usually covered by pointed papillae.

**Gynoecium:** The ovary is subinferior, which is in accordance with the usual state in Asclepiadaceae. The ovary is included in the staminal column and the corolla tube, but is coalescent with the tube, however, for only ca. one quarter of its length and it is completely superior to the calyx (Fig. 2). The ovary consists of two mostly free carpels as in Asclepiadaceae in general. There are abundant ovules on a long placenta along the entire suture. The carpels are topped by one style each, which unites immediately above the ovary into a single, distinct style of variable length. This state should be compared to the structure found in the genera *Secamone*, *Toxocarpus* and *Genianthus*, where the style head is situated directly on the ovaries with the style totally suppressed. The style broadens below the style head. The broad and short style head consists of a discoid lower part and a slightly narrower short upper part which is depressed at the apex (Fig. 2N).

**Pollinarium:** The pollinaria are situated between the thecae in a small notch at the edge of the lower discoid part of the style head. There are four ellipsoid pollinia standing erecto-patently close together but they are in fact easily separated from each other at maturity. The pollinia adhere directly to a corpusculum without caudicles (Fig. 9F). The corpusculum is inconspicuous, usually with a slit on the ventral side (opposite the pollinia).

Fruit and seeds of *Calyptranthera* have not been seen. No studies have been made on the karyology.

## PHYLOGENY

### Methods

The phylogeny presented below is based on the major morphological traits found within the genus. Several autapomorphies are also presented in the cladogram, as well as the synapomorphies characterizing *Calyptranthera*. The phylogenetic analysis was made using the parsimony program PAUP version 3.1 by SWOFFORD (1991). All data have been coded as being of equal weight.

### Tribe Secamoneae and position of *Pervillea* and *Calyptranthera*

A tentative cladogram of the tribe Secamoneae showing the position of *Calyptranthera* was recently presented by KLACKENBERG (1996b: fig. 1). Both *Pervillea* and *Calyptranthera* lack a thick lower part of the style head placed directly on the ovary without a style, which is a character found in the remaining genera within the tribe Secamoneae. This is considered a synplesiomorphy for these two genera. In contrast, anthers with prolonged connectives are a synapomorphy for *Pervillea* and *Calyptranthera* and these genera are

TABLE 1.—Data matrix: 0 = plesiomorphy; 1 or 2 = apomorphies; 0/1 = polymorphism. For description of characters see text.

	1	2	3	4	5	6	7	8	9	10	11	12	13	14	15	16	17	18
1 <i>C. caudiclava</i>	1	0/1	0	0	1	1	0	1	1	2	0	2	1	1	1	1	1	1
2 <i>C. grandiflora</i>	1	0	1	0	1	1	1	2	1	1	1	2	0	0	1	1	1	1
3 <i>C. baronii</i>	1	0	1	0	1	1	1	2	1	1	1	2	0	0	1	1	1	1
4 <i>C. brevicaudata</i>	1	1	0	0	0	0	0	2	1	2	0	1	0	0	1	0	1	1
5 <i>C. pubipetala</i>	1	1	0	1	0	0	0	2	1	2	0	1	0	0	1	0	1	1
<i>S. sulfurea</i>	0	0	0	0	0	0	0	0	0	0	0	0	0	0	0	0	0	0

proposed to be sister taxa (KLACKENBERG 1996b).

**Outgroups and analyses**

The outgroup used to analyse *Calyptranthera* was chosen from among the Malagasy *Secamone*, viz. *S. sulfurea*. This taxon was described originally as a species of *Toxocarpus* but was recently transferred to *Secamone* (KLACKENBERG 1996b). For a further discussion on the outgroup see KLACKENBERG (1996b: 168).

Data from 18 characters, including autapomorphies, were derived from vegetative (1) and floral parts (17), respectively. The characters are described below and the character distribution within the taxa is presented in the data matrix in Table 1. A cladistic analysis including all characters resulted in one most parsimonious tree 22 steps long. This tree has, with uninformative characters excluded, CI = 0.96 and RI = 0.93. It is presented in Fig. 3.

**Characters used for the cladistic analysis and comments on morphology**

*Leaves*

1. Stipules long filiform (1); stipules triangular (0).—Filiform stipules have been observed only in *Pervillea* and *Calyptranthera* within Secamoneae. However, this might represent a synplesiomorphy for these two genera, as it occurs also in Periplocoideae. The filiform stipules are easily detached and, in *Pervillea*, are hidden in the indumentum.

*Inflorescence*

2. Inflorescence condensed, ± umbelliform (1); inflorescence with elongate internodes (0).—This character, more or less condensed inflorescences, has several parallelisms within the tribe Secamoneae.

*Corolla*

3. Corolla large, lobes > 3 cm long (1); corolla small, lobes < 1.5 cm long (0).—The large gap in size between small and large corollas make this character usable. *C. baronii* and *C. grandiflora* have distinctly larger flowers than any known species within tribe Secamoneae.

4. Corolla lobe pubescent all over its upper surface (1); lobes glabrous except for a tuft of hairs near the mouth (0).—This is an autapomor-

phy for *C. pubipetala*. Pubescent corolla lobes are characteristic also for the genus *Genianthus* within the tribe Secamoneae (KLACKENBERG 1995).

- 5. Long straight erect hairs with somewhat bulbous apex present on upper corolla surface (1); all hairs on corolla with tapering apex (0).
- 6. Submarginal straight lines of hairs near the base of the corolla lobes (1); no such line (0).
- 7. Left margin (seen from above) of corolla lobe ciliate (1); margins of corolla lobe glabrous (0).
- 8. Corolla lobes with 7 more or less parallel nerves from base to tip (2); lobes with 3 straight nerves from base to tip (1); lobes with 1 main nerve (0).—This character is coded as ordered.

*Androecium*

- 9. Coronal lobes shortly fused with the anther, directed outwards at base (1); coronal lobes fused with the anther for a longer part, parallel to the anther (0).
- 10. Coronal lobes ± spatulate (2); coronal lobes

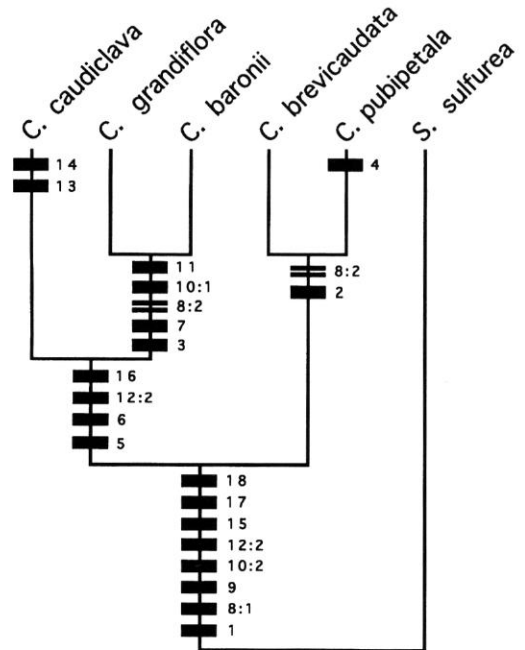

Fig. 3.—Most parsimonious cladogram of *Calyptranthera*. The apomorphies are indicated with bars and parallelisms with double lines. The numbers refer to characters explained in text. A data matrix of the characters is shown in Table 1.

filiform (1); coronal lobes narrowly rectangular to narrowly triangular, flattened (0).—This character is coded as unordered. Both the spatulate and the filiform coronal lobes are unique to *Calyptranthera* within the tribe.

11. Coronal lobes elongated, > 2 mm long (1); coronal lobes shorter, < 1.5 mm long (0).
12. Connectives long protruding above the staminal column, much longer than the thecae (2); connectives only slightly prolonged,  $\pm$  of same length as the thecae (1); connectives not prolonged (0).—This character is coded as ordered. *Pervillea* excepted, the anthers of other *Secamoneae* are at most topped by a membranaceous appendage.
13. Connectives with broadened fused bases forming a calyptra above the style head (1); bases of connectives not broadened and fused as above (0).—This character is an autapomorphy for *C. caudiclava* and is not found elsewhere within the tribe.
14. Connectives topped by club-shaped processes on filiform appendages (1); connectives of uniform thickness or narrowed towards apex (0).—This character is an autapomorphy for *C. caudiclava* and is not found elsewhere within the tribe.
15. Neighbouring filaments protruding below each pair of anther wings forming a cup together (pollinium entrance) (1); filaments more or less even (0).—This character is unique to *Calyptranthera* within the tribe *Secamoneae*.
16. Anther filaments forming a long cylinder below the pollinium entrances (1); anther filaments shorter (0).

#### Gynoecium

17. Style present (1); style absent (0).—The style head is situated directly on the ovary in most *Secamoneae*. *Calyptranthera* and *Pervillea*, however, are characterized by having a style that gradually broadens into a style head. In a broader context, this is probably a synplesiomorphy, as this condition is often found in *Periplocoideae*. *Secamone stylosa* also has a more or less distinct style.
18. Style head with short and broad upper part (1); style head with long protruding upper part (0).—The style head varies greatly in *Secamoneae* but all taxa close to the outgroup,

i.e. the three other species in the *Secamone toxocarpoides* group, as well as in the probably closely related *S. ankarensis* groups of five species (see KLACKENBERG 1992a), have a long protruding upper part. The general structure of the style head, however, is similar to what is often found in *Periplocoideae*, and might represent the plesiomorphic state.

## PHYTOGEOGRAPHY

All five known species of *Calyptranthera* are distributed along the East coast of Madagascar, all in the Eastern Domain (for definition of phyto-geographical regions, see HUMBERT 1955) except for *C. baronii* which has been collected at an unspecified locality on the Central Plateau (Central Domain). The vicariance deduced from the cladogram (Fig. 3) and the distribution of the species (Fig. 10) shows a north-south pattern (Fig. 4). A north-south vicariance in Madagascar has also been observed in *Tachadenus* (*Gentianaceae*) (KLACKENBERG 1987) and *Pervillea* (*Asclepiadaceae*) (KLACKENBERG 1996b). The analyses of *Tachadenus* and *Pervillea* have shown that this vicariance is recent, but with an older underlying east-west

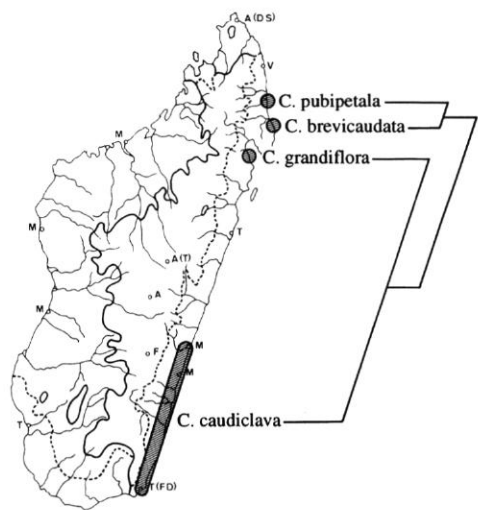

Fig. 4.—Phylogeographical vicariance pattern of *Calyptranthera*.

vicariance between the Domains. Except for *C. baronii* which is known only from an old BARON collection without specific place of collection, the *Calyptranthera* species show a similar north-south vicariance along the east coast as was found in *Tachiadenus* (KLACKENBERG 1987), but with different areas of endemism. In *Calyptranthera* there is a vicariance between the coast north of the Masoala Peninsula and the rest of the Eastern Domain south to Tolanaro (Fort Dauphin) (Fig. 4). This vicariance has not been observed earlier and is not supported by the vast majority of known species distributions. It must be noted, however, that each of the five species of *Calyptranthera* has been collected only once, except for *C. caudiclava* which is known from four collections, and all phytogeographical analyses are uncertain. There might also be ecological vicariance involved.

**TAXONOMY**

**CALYPTRANTHERA** Klack.

Novon 6: 27 (1996).

TYPE.—*Calyptranthera caudiclava* (Choux) Klack. (= *Toxocarpus caudiclavus* Choux).

Suffrutescent twiners with milky latex, covered with more or less straight to bent, often retrorse, rather stiff reddish hairs, glabrescent. Leaves opposite, somewhat coriaceous, usually revolute at the very margin, covered with more or less straight to bent reddish hairs but with upper side of lamina glabrescent, shining above, paler below; blade oblong to obovate or broadly elliptic, cuneate to truncate but sometimes minutely cordate at the very base, acuminate to apiculate or rounded at the apex, often with truncate glands at the very base above; margin entire; venation pinnate and looped, reticulate; midrib distinctly raised below, impressed above when dry; primary veins distinctly raised on both sides; secondary veins reticulate and raised below but indistinct above when dry; epidermis ± smooth on both sides; petiole distinct, often twisted; stipules filiform. Inflorescences extra-axillary, about

as long as to usually shorter or much shorter than the adjacent leaves; cyme lax to rather condensed and then ± umbel-like, with few flowers at one time, hairy; bracts present. Flowers pentamerous, actinomorphic. Calyx lobes free, longer than the corolla tube, narrowly triangular to narrowly ovate or linear, acute, with long straight hairs outside, glabrous inside. Corolla elliptic in bud, contorted with the left lobe margin overlying, not twisted, with the lobes fused at the base only into a short wide glabrous tube, purple-lavender to rose or greenish with reddish spots; lobes oblong to usually elliptic, rounded at the apex, inside pubescent near base or rarely to tip. Stamens in a column inserted at the base of the corolla tube; filaments broad with horny margins (anther wings) and with a cup-like projection below (pollinium entrance), basally coalescent forming a ± long cylinder; connectives prolonged, prolongation short and triangular to very long and filiform forming a cone above the style head or sometimes much broadened and adhering to each other forming a calyptra above the thecae crowned by five distinct clubs on long strings, papillate and the broadened ones sometimes also hairy. Coronal lobes of staminal column single, filiform and projecting above the prolonged connectives or spatulate and shorter than the thecae, directed upwards to ± horizontally, papillate. Pollinaria with 4 pollinia each; pollinia minute, two in each anther locule, ascending to almost horizontal, ellipsoidal, attached on U-folded soft corpuscula at the margin of a discoid style head. Ovary subinferior, with numerous ovules. Style conical or narrow and cylindrical but conical just below the style head; style head with a discoid lower part which abruptly narrows into the style and with a narrower and short upper part which is usually slightly depressed at the apex, hidden by the staminal cone. Follicles not seen.

**Key to the species**

- 1. Corolla 6 cm or more in diameter; coronal lobes ± filiform ..... 2
- 1'. Corolla less than 4 cm in diameter; coronal lobes spatulate ..... 3



2. Coronal lobes longer than the connectives; corolla 6 to 7 times longer than the calyx ..... 2. **C. grandiflora**
- 2'. Coronal lobes shorter than the connectives; corolla 4 to 5 times longer than the calyx ..... 3. **C. baronii**
3. Staminal column topped by a cap which is formed by the prolonged fused connectives and with 5 free  $\pm$  club-shaped appendages at apex much longer than the thecae ..... 1. **C. caudiclava**
- 3'. Anthers with only shortly projecting free connectives and without club-shaped appendages; projecting part of connectives  $\pm$  of the same length or shorter than the thecae ..... 4
4. Corolla lobes shaggy inside in addition to a patch of straight  $\pm$  erect hairs near the base; corolla 1-1.5 cm in diameter ..... 5. **C. pubipetala**
- 4'. Corolla lobes glabrous except for a patch of straight  $\pm$  erect hairs near the base; corolla ca. 2 cm in diameter ..... 4. **C. brevicadata**

### 1. *Calyptranthera caudiclava* (Choux) Klack.

Novon 6: 27 (1996).

*Toxocarpus caudiclavus* Choux, Ann. Inst. Bot.-Géol. Colon. Marseille, sér. 3, 2: 415 (1914).—Type: *Perrier de la Bâthie 11747* (lecto-, P).

Suffrutescent twiner with somewhat coriaceous leaves. Leaf blade 6-14  $\times$  3.5-5.5 cm, oblong to obovate or broadly elliptic, cuneate to truncate but sometimes minutely cordate at the very base, acuminate to apiculate or rounded at the apex, hairy beneath, glabrescent above, without or with one colletar at the very base above; primary veins distinctly raised on both sides; secondary veins reticulate and raised below but indistinct above when dry; petiole 0.5-1 cm long, when young densely hairy, glabrescent. Inflorescences shorter than the adjacent leaves; cyme lax; pedicels in pairs, 1-2 cm long; bracts 2-3 mm long. Calyx lobes 2-3.6  $\times$  0.9-1.6 mm, longer than the corolla tube, ovate-triangular. Corolla purple-lavender to rose or greenish with reddish spots; tube 0.4-0.8 mm long; lobes 9-13.5  $\times$  2.5-6.8 mm, oblong to elliptic, rounded at the apex, glabrous outside or with a few scattered longer reddish hairs, glabrous inside except for a patch of straight erect white hairs

both centrally and with even longer distinct hairs submarginally in a 1.3-2 mm broad zone 1.3-1.5 mm from the base; margins glabrous. Staminal column in total 8-10 mm high; filament cylinder below the pollinaria entrances distinct; anthers with connectives excluded 1-2.3 mm long, glabrous or with thecae strongly papillate; connectives much prolonged, fused and broadened below forming a cone above the thecae and crowned with five free filiform to  $\pm$  club-like appendages, glabrous or with especially the lower fused part papillate and hairy. Corona lobes somewhat spatulate, ca. 1 mm long, truncate at the apex, bent outwards, much shorter than the connectives, glabrous. Pollinia 0.15-0.2 mm long. Style narrow and cylindrical below but slightly conical below the style head, 1.2-1.5 mm high; style head 0.35-0.5 mm high.—Fig. 5, 10.

DISTRIBUTION.—Southeastern part of Madagascar, occurring from Tolanaro to Mananjary.

HABITAT.—In rain forest from sea level up to 300 m altitude. Flowering specimens seen from October and January to March.

*Calyptranthera caudiclava* is the only species known from southern Madagascar. It differs from all other species by having widened connectives adhering to each other forming a distinct calyptra above the staminal column. At the top of the calyptra the connectives are filiform and free from each other with more or less club-shaped apices. The calyptra varies in length from ca. 2 mm and rather abruptly narrowed at top (Fig. 5D<sup>''</sup>) to ca. 2.5 mm and more attenuate at top (Fig. 5D<sup>'</sup>). Furthermore, the calyptra can be covered by papillae and scattered longer hairs (Fig. 5D<sup>''</sup>) or can be totally glabrous (Fig. 5D<sup>'</sup>). This variation in the morphology of the calyptra does not show any geographical pattern and is considered to represent an intraspecific variation.

SPECIMENS EXAMINED.—*Capuron 28969*, Bemangily - 70 km au Nord de Tolanaro (P); *Dorr 4018*, Tolanaro, forêt de Mandena, 1985 (MO, P); *Dumetz 1188*, Préfecture de Tolanaro, Ste. Luce (Nord), 1990

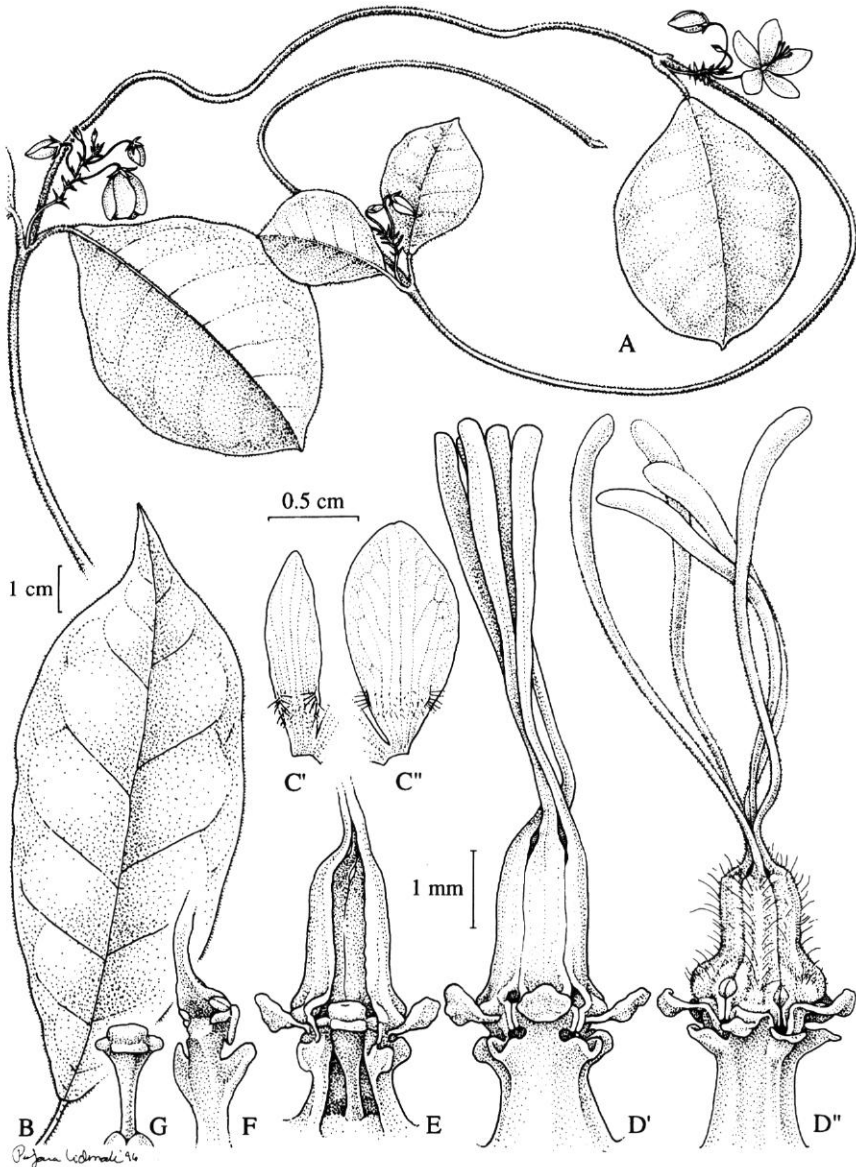

Fig. 5.—*Calyptranthera caudiclava* (Choux) Klack.: A, habit; B, leaf; C, corolla with petal lobe and portion of tube from within; D, gynostegium; E, part of gynostegium with one anther removed; F, anther seen in lateral view slightly from the inside with pollinarium; G, style head. (A, Dorr 4018; B, C', Perrier 11747; C'', D', E-G, Dumetz 1188; D'', Capuron 28969).

(MO, P); Perrier de la Bâthie 11747, Forêt orientale, Mt. Vatovavy, 300 m, 1911 (P).

**2. *Calyptranthera grandiflora* Klack., sp. nov.**

*Species haec C. baronii similis sed corollis majoribus*

*autem lobis calycis brevioribus et lobis coronae connectiva prolongata superantibus differt; species duae a C. caudiclava floribus magnis, lobis coronae filiformibus et margine dextro (externe visus) lobi corollae ciliato differt.*

TYPUS.—SF-18229bis Capuron, environs de la baie d'Antongil, à l'ouest d'Anandrovola, "Anandrivola" (holo-, P).

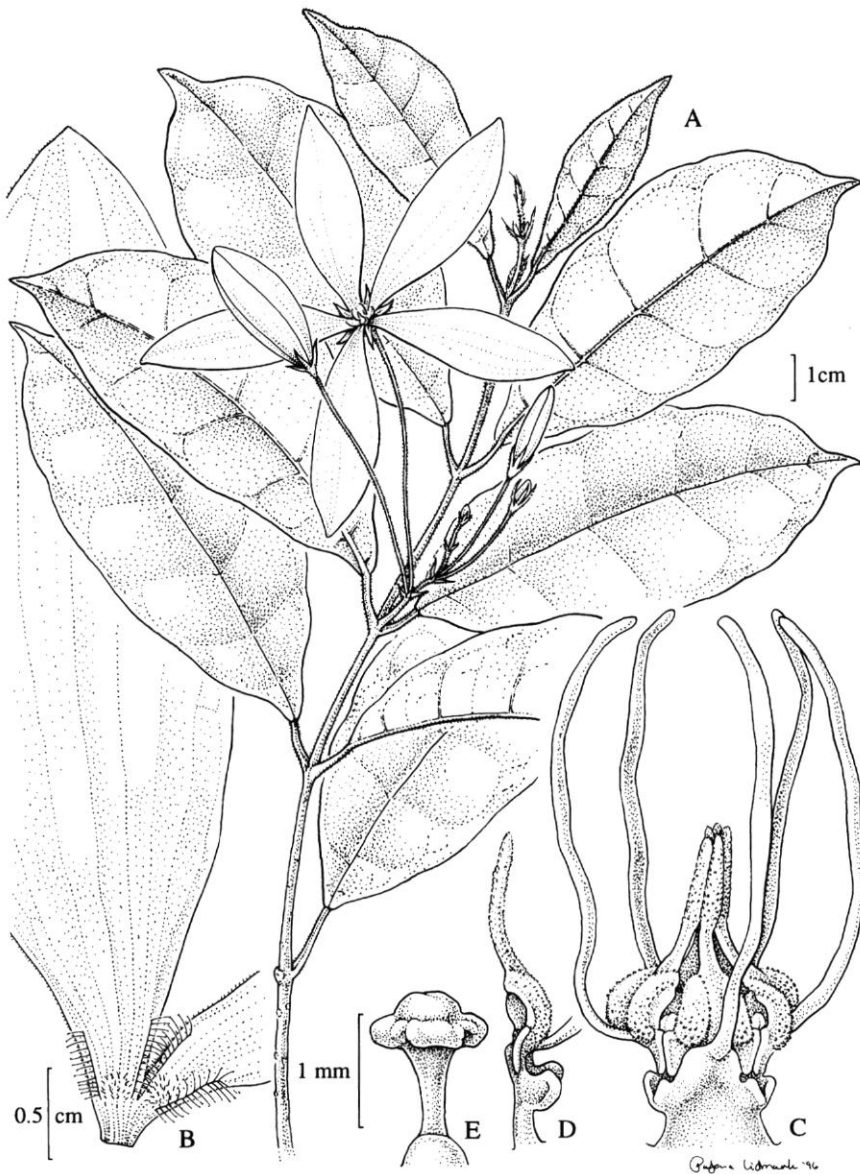

Fig. 6.—*Calyptanthera grandiflora* Klack.: A, habit; B, portion of corolla from within; C, gynostegium; D, anther seen in lateral view; E, style head. (*Capuron 18229bis*).

Suffrutescent twiner with somewhat coriaceous leaves. Leaf blade 10-12 × 4-6 cm, oblong to slightly obovate, cuneate at the base, acuminate, hairy beneath becoming sparse, glabrescent above, without colleters at the very base above; primary veins distinctly raised on both sides; secondary veins reticulate and raised below but

indistinct above when dry; petiole 0.7-1 cm long, when young with dense reddish hairs, glabrescent. Inflorescences shorter than the adjacent leaves; cyme lax; pedicels in pairs, 4-6 cm long; bracts up to 7 mm long. Calyx lobes 7.4 × 1.4 mm, much longer than the corolla tube, narrowly ovate. Corolla of unknown

colour; tube ca. 0.7 mm long; lobes ca. 50 × 15 mm, elliptic, acute but rounded at the very apex, glabrous outside, glabrous inside except for a patch of straight erect white hairs near the base both centrally and with even longer distinct hairs submarginally for ca. 4 mm; left margin finely pubescent. Staminal column in total ca. 2.7 mm high; filament cylinder below the pollinaria entrances distinct; anthers with connectives excluded ca. 1.3 mm long, strongly papillate along the margin of the thecae; connectives adhering to each other at upper part and projecting well above the thecae forming a cone but free from each other basally and without ± club-like free appendages, inside glabrous, outside papillate above, glabrous below. Corona lobes filiform, ca. 5 mm long, bent outwards-upwards, longer than the connectives, somewhat papillate. Pollinia ca. 0.2 mm long. Style narrowly conical, ca. 0.8 mm high; style head ca. 0.5 mm high.—Fig. 6, 10.

**DISTRIBUTION.**—Northeastern part of Madagascar, known only from the type locality at Baie d'Antongil south of Maroansetra.

**HABITAT.**—In forest between 100 and 150 m altitude. Flowering specimen seen from November.

*Calyptranthera grandiflora* is characterized by its large flowers and thread-like corona lobes, which are distinctly longer than the connectives. See also *C. baronii*.

### 3. *Calyptranthera baronii* Klack., sp. nov.

*Species haec C. grandiflorae similis sed corollis minoribus autem lobis calycis longioribus et connectiviis prolongatis lobos corollae superantibus differt; species duae a C. caudiclavata floribus magnis, lobis corollae filiformibus et margine dextro (externe visus) lobi corollae ciliato differt.*

**TYPUS.**—*Baron 3008*, Central Madagascar (holo-, K; iso-, P).

Suffrutescent twiner with somewhat coriaceous

leaves. Leaf blade ca. 6-8 × 4-5 cm, elliptic to slightly obovate, cuneate at the base, acuminate, hairy along the nerves beneath, rather sparsely hairy above but densely so along the mid-nerve, without colleters at the very base above; primary and the reticulate secondary veins distinctly raised on both sides when dry; petiole ca. 1 cm long, with dense reddish hairs. Inflorescences slightly shorter than the adjacent leaves; cyme lax; pedicels in pairs, 3-4 cm long; bracts up to 1 cm long. Calyx lobes ca. 9.2 × 1.1 mm, much longer than the corolla tube, linear. Corolla of unknown colour; tube ca. 0.7 mm long; lobes ca. 35 × 8 mm, elliptic, acute but rounded at the very apex, glabrous outside, glabrous inside except for a patch of straight erect white hairs near the base both centrally and with even longer distinct hairs submarginally for ca. 4.7 mm; left margin finely pubescent. Staminal column in total ca. 4.5 mm high; filament cylinder below the pollinaria entrances distinct; anthers with connectives excluded ca. 1.5 mm long, strongly papillate along the margin of the thecae; connectives free from each other projecting well above the thecae without ± club-like appendages, papillate on both sides from base to top. Corona lobes filiform, ca. 2.7 mm long, bent outwards-upwards, shorter than the connectives, somewhat papillate. Pollinia ellipsoid, ca. 0.15-0.20 mm long. Style narrowly conical, ca. 0.8 mm high; style head ca. 0.5 mm high.—Fig. 7, 10.

**DISTRIBUTION.**—Known only from the type collected without specific locality in Central Madagascar.

**HABITAT.**—There is no information on habitat or flowering period.

*Calyptranthera baronii* is close to *C. grandiflora* but has smaller corolla and longer calyx. The calyx lobes are linear in *C. baronii* but narrowly ovate in *C. grandiflora*. It has long filiform coronal lobes and prolonged connectives as in *C. grandiflora* but contrary to the latter species the connectives are longer than the coronal lobes. Both species are finely hairy along the left lobe margins.

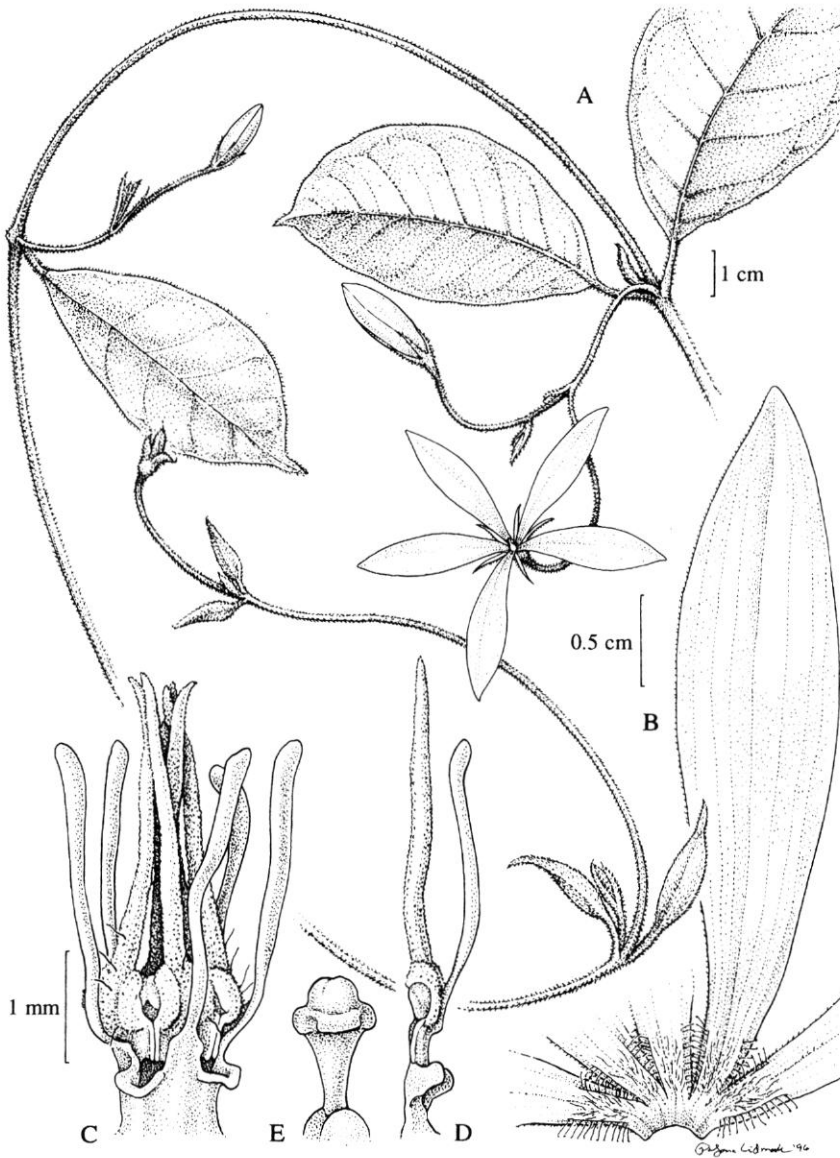

Fig. 7.—*Calyptranthera baronii* Klack.: A, habit; B, portion of corolla from within; C, gynostegium; D, anther seen in lateral view; E, style head. (Baron 3008).

#### 4. *Calyptranthera brevicaudata* Klack., sp. nov.

*Species haec C. pubipetalae similis sed lobis corollae majoribus vel basibus non nisi hirsutis differt; species duae a C. caudiclava connectivis triangularibus breve prolongatis (sine calyptra) et lobis corollae con lineis rectis submarginalibus piliferis destitutis differt.*

TYPUS.—SF-27713bis Capuron, au sud de Sambava, 1-10 avr. 1967 (holo-, P).

Suffrutescent twiner with somewhat coriaceous leaves. Leaf blade 7-12 × 4-6 cm, oblong to elliptic, cuneate to almost truncate at the base, acuminate, hairy beneath, glabrescent above,

without colleters at the very base above; primary and secondary veins distinctly raised on both sides when dry; petiole ca. 1-1.5 cm long, densely hairy. Inflorescences much shorter than the adjacent leaves; cyme umbel-like with reduced internodes on a short stalk, when older elongated with distinct scars of earlier umbels; pedicels of

different length, up to 3 cm long; bracts 2-3 mm long. Calyx lobes ca.  $2.7 \times 1.5$  mm, longer than the corolla tube, ovate-triangular. Corolla of unknown colour; tube ca. 0.4 mm long; lobes ca.  $12 \times 5.5$  mm, elliptic, rounded at the apex, glabrous outside, with a patch of longer straight  $\pm$  erect white hairs near the base inside but without

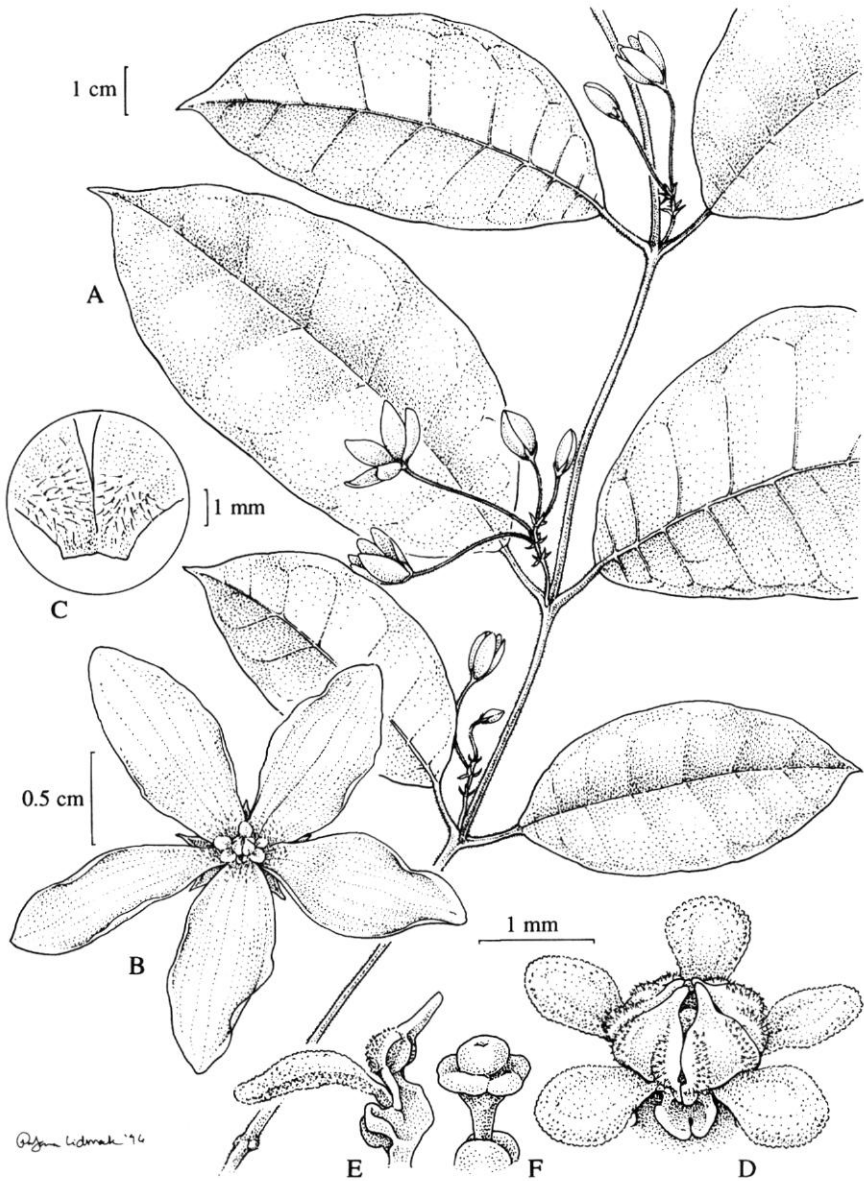

Fig. 8.—*Calyptranthera brevicaudata* Klack.: A, habit; B, flower; C, basal part of corolla from within; D, gynostegium; E, anther seen in lateral view; F, style head. (SF-27713bis).

a line of long straight submarginal hairs; margins glabrous. Staminal column ca. 1.5 mm high; filament cylinder below pollinaria entrances very short; anthers with connectives excluded ca. 1 mm long, strongly papillate along the margin of the thecae; connectives only slightly projecting above the thecae, free, papillate. Corona lobes

spatulate, ca. 1.3 mm long, truncate at the apex, bent outwards,  $\pm$  of the same length as the connectives, papillate. Pollinia ca. 0.2 mm long. Style narrow and cylindrical at lower half but slightly conical below the style head, ca. 0.35 mm high; style head ca. 0.4 mm high.—Fig. 8, 10.

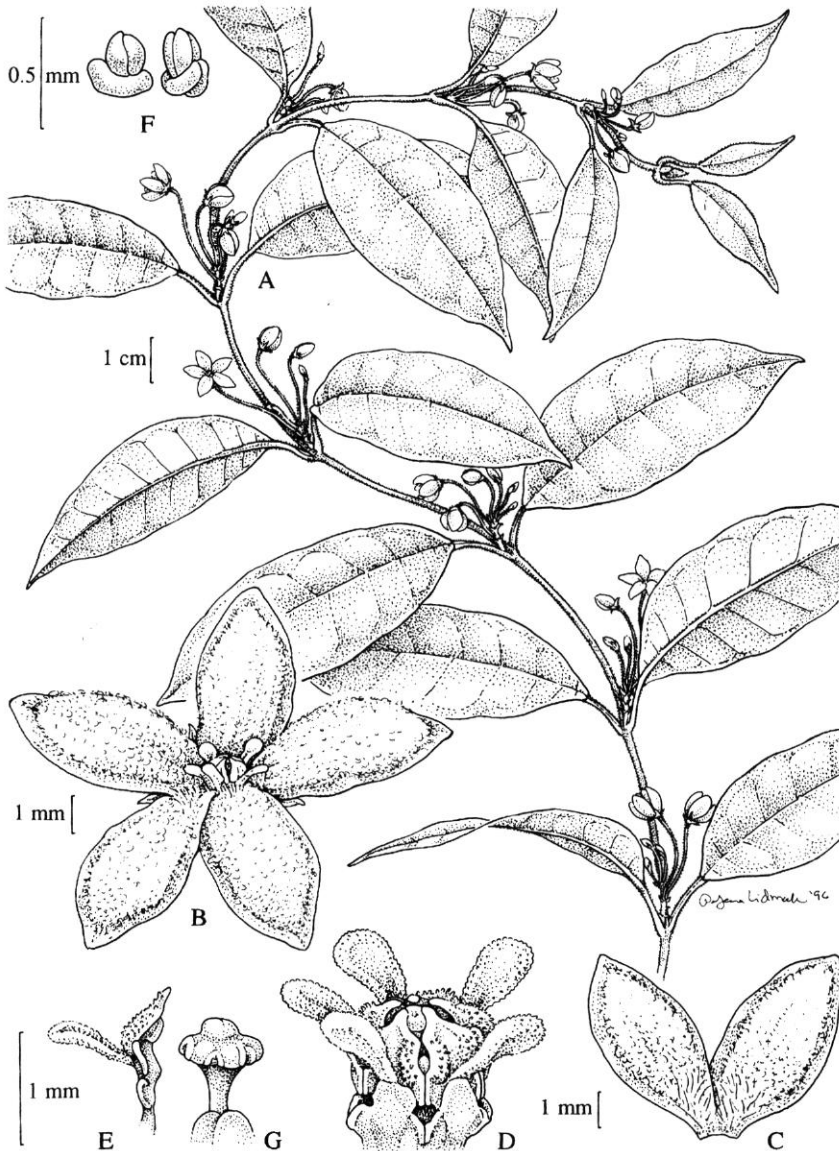

Fig. 9.—*Calyptranthera pubipetala* Klack.: **A**, habit; **B**, flower; **C**, portion of corolla from within; **D**, gynostegium; **E**, anther seen in lateral view; **F**, pollinaria; **G**, style head. (RN-5702).

**DISTRIBUTION.**—Northeastern Madagascar, known only from the type from near Sambava.

**HABITAT.**—In coastal forest on sand. Flowering specimens seen from April.

*Calyptranthera brevicaudata* and *C. pubipetala* are both characterized by having short triangular connectival prolongations. *C. brevicaudata* is distinguished, however, by its larger and mostly glabrous corolla, with a patch of longer hairs only near the mouth. It probably also differs by its habitat (coastal forest in sand).

### 5. *Calyptranthera pubipetala* Klack., sp. nov.

*Species haec C. brevicaudata similis sed corollis minoribus vel intra tomentulosis differt; species duae a C. caudiclava connectiviis triangularibus breve prolongatis (sine calyptra) et lobis corollae con lineis rectis submarginalibus piliferis destitutis differt.*

**TYPUS.**—RN-5702, Distr. Antalaha, Cant. Ambohitralanana, RN2, 5 oct. 1953 (holo-, P; iso-, P).

Suffrutescent twiner with somewhat coriaceous leaves. Leaf blade ca. 5-8 × 3-3.5 cm, oblong to broadly elliptic, cuneate to truncate at base, acuminate, hairy beneath, glabrescent above or with a few remaining hairs especially along the midrib, without colleters at the very base above; primary and the reticulate secondary veins distinctly raised on both sides when dry; petiole 0.5-1 cm long, with dense erect reddish hairs. Inflorescences much shorter than the adjacent leaves; cyme umbel-like with reduced internodes on a short stalk, when older elongated with distinct scars of earlier umbels; pedicels of different length, up to 2 cm long; bracts 2-3 mm long. Calyx lobes ca. 2.4 × 1.1 mm, longer than the corolla tube, ovate-triangular. Corolla of unknown colour; tube ca. 0.4 mm long; lobes ca. 5.5-6.5 × ca. 3 mm, elliptic, rounded at the apex, glabrous outside, shaggy inside but with glabrous right margin and with longer straight ± erect white hairs near the base but without a line of long straight submarginal hairs; margins glabrous. Staminal column ca. 1.3 mm high; fila-

ment cylinder below pollinaria entrances very short; anthers with connectives excluded ca. 0.9 mm long, strongly papillate along the margin of the thecae; connectives triangular, only slightly projecting above the thecae, free, papillate on both sides. Corona lobes spatulate, ca. 1 mm long, truncate at the apex, bent outwards, longer than the connectives, papillate. Pollinia ca. 0.15 mm long. Style narrow and cylindrical at lower half but slightly conical below the style head, ca. 0.5 mm high; style head ca. 0.4 mm high.—Fig. 9, 10.

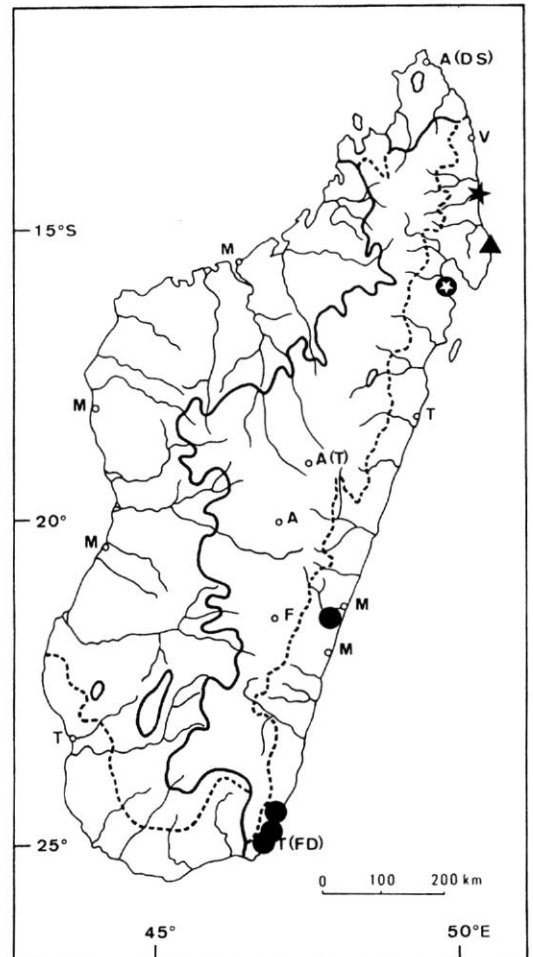

Fig. 10.—Distribution of *Calyptranthera caudiclava* (●), *C. grandiflora* (⊛), *C. pubipetala* (▲) and *C. brevicaudata* (★).



**DISTRIBUTION.**—Northeastern part of Madagascar, known only from the type locality at Masoala peninsula.

**HABITAT.**—Savoka. Flowering specimen seen from October.

*Calyptranthera pubipetala* differs from *C. caudiclava* by lacking a calyptra above the anthers as well as a submarginal straight line of bulbous hairs on the corolla and furthermore by its condensed inflorescence. In these characters it is similar to *C. brevicaudata*. It differs from all *Calyptranthera* by having the corolla lobes almost entirely pubescent.

#### Acknowledgments

I wish to thank Dr. David GOYDER, Kew, for improving the manuscript and Ms. POLLYANNA LIDMARK, Stockholm, for providing the illustrations. Financial support for part of this study has been given by grants from the Royal Academy of Sciences (J.A. Wahlbergs Minnesfond) and from Uddenberg-Nordingska stiftelsen.

#### REFERENCES

- HOLMGREN P.K., HOLMGREN N.H. & BARNETT L.C. 1990.—*Index Herbariorum 1. The Herbaria of the World*, ed. 8. *Regn. Veg.* 120, New York.
- HUMBERT H. 1955.—Les territoires phytogéographiques de Madagascar. *Année Biol.*, sér 3, 31: 439-448.
- KLACKENBERG J. 1987.—Revision of the genus *Tachadenus* (Gentianaceae). *Bull. Mus. Natl. Hist. Nat., B, Adansonia* 9: 43-80.
- KLACKENBERG J. 1992a.—Taxonomy of *Secamone* s.lat. (Asclepiadaceae) in the Madagascar Region. *Opera Botanica* 112: 1-127.
- KLACKENBERG J. 1992b.—Taxonomy of *Secamone* (Asclepiadaceae) in Asia and Australia. *Kew Bull.* 47: 595-612.
- KLACKENBERG J. 1995.—Taxonomy and phylogeny of the SE Asian genus *Genianthus* (Asclepiadaceae). *Bot. Jahrb. Syst.* 117: 401-467.
- KLACKENBERG J. 1996a.—The new genus *Calyptranthera* (Asclepiadaceae) from Madagascar. *Novon* 6: 25-27.
- KLACKENBERG J. 1996b.—Revision of the Malagasy genus *Pervillea* (Asclepiadaceae) and its phylogenetic relationship to *Calyptranthera*. *Nord. J. Bot.* 16: 165-184.
- SWOFFORD D.L. 1991.—*PAUP, Phylogenetic Analysis Using Parsimony*. Champaign, Illinois, Computer program distributed by the Illinois Natural History Survey.

*Manuscript received 2 September 1996;  
revised version accepted 25 February 1997.*